



Ersatzteile-Liste
Parts List
Catalogo Ricambi

Nr.
No. **470**

Motor **Type**
Engine **Type**
Motore **Tipo**

244 MC LC



Ausgabe
Edition **1984**
Edizione



BOMBARDIER-ROTAX GMBH
MOTORENFABRIK
A-4623 Gunkskirchen – Austria
Telefon: (07246) 271-0*, Telex: 25546 brgk a
Telegrammadresse: Bombrotax Gunkskirchen



Inhaltsverzeichnis, / Table of Contents / Indice dei Capitoli

Seite	
Page	
Pagina	
3	Gehäuse, Drehschieberdeckel Crankcase, Disk Valve Cover Carter Motore, Coperchio Valvola
7	Kurbelwelle, Kolben, Zylinder, Zylinderkopf Crankshaft, Piston, Cylinder, Cylinder Head Albero Motore, Pistone, Cilindro, Testa Cilindro
11	Getriebe Transmission Trasmissione
15	Kupplung, Kickstarter Clutch, Kick Start Frizione, Messa in Moto
19	Zünderdeckel, Kupplungsdeckel, Wasserpumpe, Kupplungsausrücker mit 7/32" Kugeln Magneto Cover, Clutch Cover, Water Pump, Cam assy. with 7/32" balls Coperchio Volano, Coperchio Frizione, Pompa Acqua, Chiocciola con Sfere 7/32"
23	Zünderdeckel, Kupplungsdeckel, Wasserpumpe, Kupplungsausrücker mit 12 mm Kugeln Magneto Cover, Clutch Cover, Water Pump, Cam assy. with 12 mm balls Coperchio Volano, Coperchio Frizione, Pompa Acqua, Chiocciola con Sfere 12 mm
27	Magnetzündler-Generator 12V 60W Magneto-Generator 12V 60W Volano 12V 60W
31	MIKUNI-Vergaser MIKUNI-Carburetor Carburatore MIKUNI
35	BING-Vergaser BING-Carburetor Carburatore BING
39	Werkzeug Tools Attrezzi

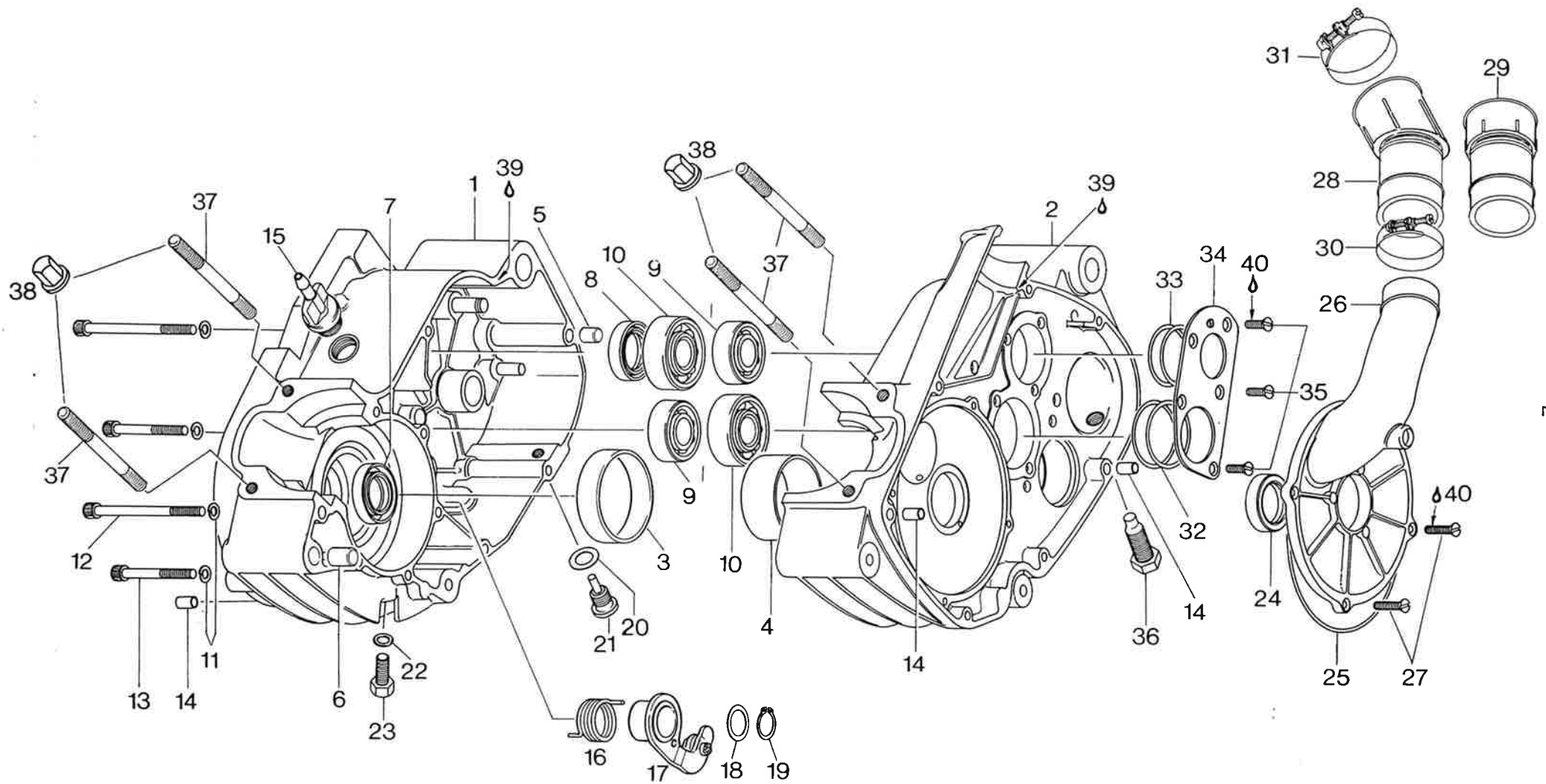

Gehäuse, Drehschieberdeckel
Crankcase, Disk Valve Cover
Carter Motore, Coperchio Valvola

Bild-Nr. Ill. No. Fig.	Teile-Nr. Part No. Codice	B e z e i c h n u n g D e s c r i p t i o n D e s c r i z i o n e	Stück Qty Qtà
1 - 6	292 311	Gehäuse kpl. / crankcase assy. / coppia carter motore	1
3	960 767	Gehäusering MS / ring, crankcase, magneto side / anello teflon cuscinetto destro	1
4	260 400	Gehäusering KS / ring, crankcase, clutch side / anelle teflon cuscinetto sinistro	1
5	229 140	Paßhülse 9,8 Ø x 10 / dowel / spina . .	1
6	229 160	Paßhülse 13,8 Ø x 15 / dowel / spina . .	1
7	230 425	Wellendichtring AS 28x38x7 / oil seal / corteco	1
8	230 421	Wellendichtring AS 28x38x7 / oil seal, transmission main shaft / corteco	1
9	932 030	Rillenkugellager 6203 / ball bearing / cuscinetto	2
10	932 432	Rillenkugellager 6204 / ball bearing / cuscinetto	2
11	945 751	Federring A6 / lock washer / ranella . .	10
12	241 871	Zylinderschraube M6 x 70 / cyl. screw / vite	5
13	241 820	Zylinderschraube M6 x 45 / cyl. screw / vite	5
14	949 900	Paßhülse 8,4 Ø x 10 / dowel / spina . . .	5
15	241 920	Entlüfterschraube M18 x 1,5 / oil filler cap / tappo immissione olio	1
16	239 750	Indexfeder / spring, index / molla . . .	1
17	248 977	Rollenindex kpl. / lever with roller assy., index / leva	1
18	227 800	Anlaufscheibe 16,2/21/0,4 / washer / spessore	1
19	945 840	Sicherungsring 15 x 1 / snapring / seger	1

Bild-Nr. Ill. No. Fig.	Teile-Nr. Part No. Codice	B e z e i c h n u n g D e s c r i p t i o n D e s c r i z i o n e	Stück Qty Qtà
20	650 040	Dichtungsscheibe 12,2/20/1 / gasket ring / guarnizione	1
21	241 781	Magnetschraube M12 x 1,5 / plug, magnetic drain / tappo scarico olio	1
22	950 141	Dichtring C8x14 / gasket ring / guarnizione	1
23	940 580	Sechskantschraube M8 x 16 / screw, hex. head / vite	1
24	230 425	Wellendichtring AS 28x38x7 / oil seal / corteco	1
25	230 310	O-Ring 114-2 / O-ring / anello gomma . . .	1
26	212 430	Drehschieberdeckel / disk valve cover / coperchio valvola	1
27	940 510	Senkschraube M5 x 16 / counter-sunk screw / vite	4
28	267 890	Vergaserwinkelrohr / angular tube, carburetor / manicotto carburatore angolare	1
29	267 810	Vergaserrohr kpl. / carburetor socket / manicotto carburatore	1
30	251 845	Schlauchschelle 42 kpl. / hose clamp assy. / fascetta manicotto carburatore . .	1
31	251 820	Schlauchschelle 47 kpl. / hose clamp assy. / fascetta manicotto carburatore . .	1
32	227 610	Ausgleichscheibe 40/46,5/0,5 mm / shim 0,5 mm / spessore mm. 0,5	nach Bedarf as required a richiesta
	227 611	Ausgleichscheibe 40/46,5/0,3 mm / shim 0,3 mm / spessore mm. 0,3	- " -
	227 612	Ausgleichscheibe 40/46,5/0,1 mm / shim 0,1 mm / spessore mm. 0,1	- " -
33	227 520	Ausgleichscheibe 34/39,5/0,5 mm / shim 0,5 mm / spessore mm. 0,5	- " -
	227 521	Ausgleichscheibe 34/39,5/0,3 mm / shim 0,3 mm / spessore mm. 0,3	- " -
	227 522	Ausgleichscheibe 34/39,5/0,1 mm / shim 0,1 mm / spessore mm. 0,1	- " -
34	227 555	Halteblech / retaining plate / piastra fissaggio cuscinetti	1

Bild-Nr. Ill. No. Fig.	Teile-Nr. Part No. Codice	B e z e i c h n u n g D e s c r i p t i o n D e s c r i z i o n e	Stück Qty Qtà
35	940 315	Senkschraube M5 x 12 / counter-sunk screw / vite	5
36	241 777	Ausrückschraube M12 / screw, kick starter stop / fermo messa in moto . . .	1
37	841 350	Stiftschraube M8 x 90 / stud / colonna	4
38	842 471	Bundhutmutter M8 / cap nut / dado a cappello	4
39	899 683	Flächendichtmittel LOCTITE 515, wein- rot / LOCTITE ruby / LOCTITE rosso . . .	nach Bedarf as required a richiesta
40	899 786	Schraubensicherungsmittel LOCTITE 242, blau / LOCTITE blue / LOCTITE blu . . .	- " -

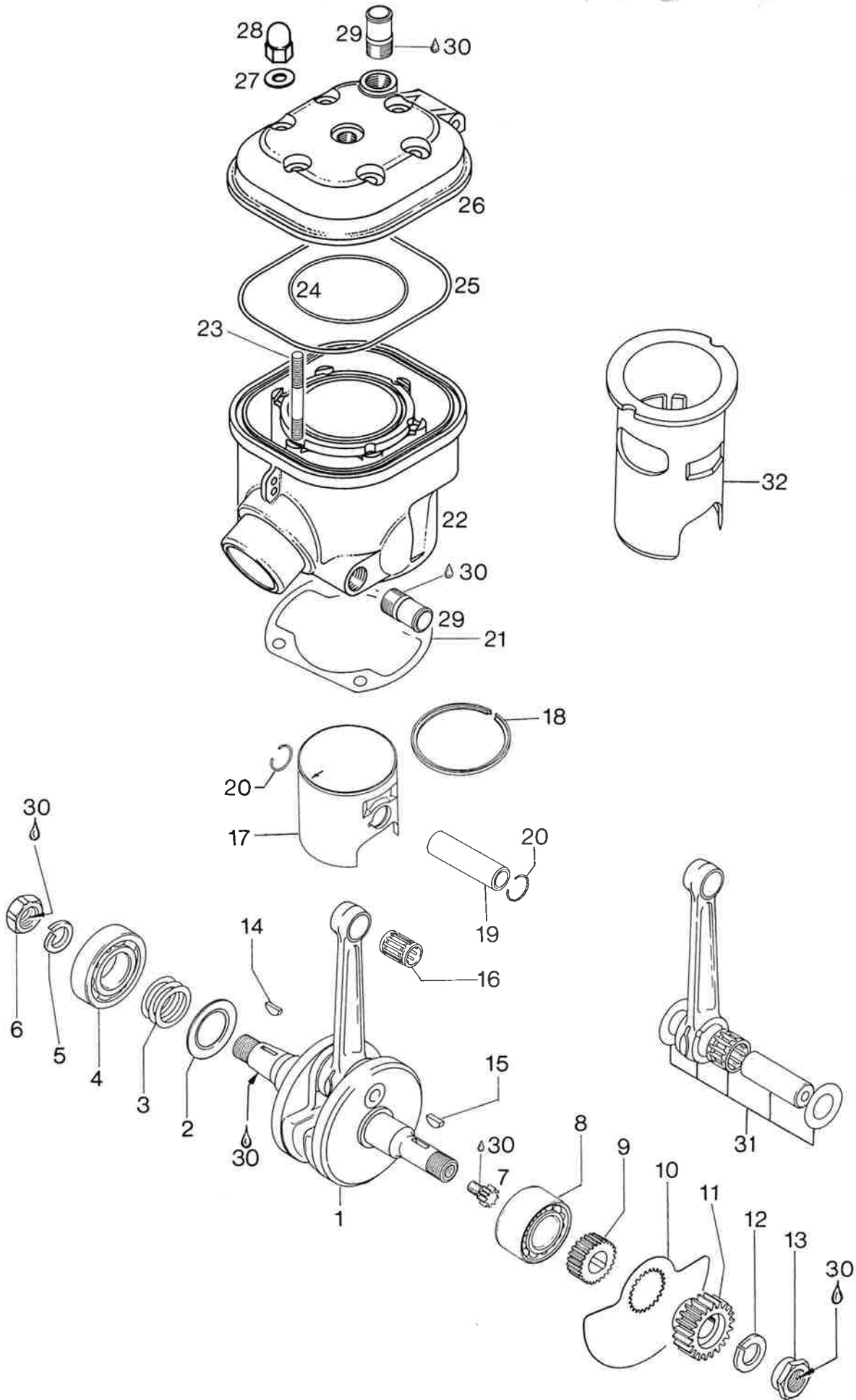

Kurbelwelle, Kolben, Zylinder, Zylinderkopf
 Crankshaft, Piston, Cylinder, Cylinder Head
 Albero Motore, Pistone, Cilindro, Testa Cilindro

Bild-Nr. Ill. No. Fig.	Teile-Nr. Part No. Codice	B e z e i c h n u n g D e s c r i p t i o n D e s c r i z i o n e	Stück Qty Qtà
1	292 027	Kurbelwelle kpl. / crankshaft assy. / albero motore	1
2	227 755	Radiusscheibe 30,9/50/0,75 / shim / spessore	1
3	944 582	Ausgleichscheibe 30,4/40,5/0,3 mm / shim 0,3 mm, crankshaft, magneto side / spessore albero motore mm. 0,3	nach Bedarf as required a richiesta
	944 583	Ausgleichscheibe 30,4/40,5/0,1 mm / shim 0,1 mm, crankshaft, magneto side / spessore albero motore mm. 0,1	- " -
	944 586	Ausgleichscheibe 30,4/40,5/0,2 mm / shim 0,2 mm, crankshaft, magneto side / spessore albero motore mm. 0,2	- " -
4	932 581	Rillenkugellager 6206 / ball bearing / cuscinetto	1
5	245 400	Federring A18 / lock washer / rondella grower	1
6	942 225	Sechskantmutter M18 x 1,5 / hex. nut / dado	1
7	234 040	Pumpenritzel 9 Z. / gear 9 t., water pump / ingranaggio 9 d. per pompa acqua .	1
8	232 750	Schrägkugellager 3205 / ball bearing / cuscinetto	1
9	247 290	Drehschieberhülse / spacer, disk valve / mozzo valvola	1
10	224 105	Drehschieber / disk valve / valvola rotante	1
11,12,13,	292 130	Primärtrieb kpl. (nur Antriebsrad und Kupplungskorb gemeinsam austauschen!) / drive gear with clutch drum assy. (re- place only drive gear with clutch drum assy.!) / ingranaggio albero motore (cambiare solo insieme ingranaggio con campana frizione!)	1
12	945 757	Federring A18 / lock washer / rondella grower	1

Bild-Nr. Ill. No. Fig.	Teile-Nr. Part No. Codice	B e z e i c h n u n g D e s c r i p t i o n D e s c r i z i o n e	Stück Qty Qtà
13	242 615	Bundmutter M18 x 1,5 / nut / dado	1
14	246 011	Scheibenfeder 3 x 5 / Woodruff key / chiavella	1
15	246 570	Scheibenfeder 4 x 5 / Woodruff key / chiavella	1
16	932 904	Kolbenbolzenkäfig / needle bearing / gabbia a rulli spinotto	1
17,18,	292 330	Kolben 72,0 Ø mit Ring, Standard / piston w. ring 72,0 Ø, standard / pistone Ø 72,0 con segmento, standard	1
	292 331	Kolben 72,25 Ø mit Ring, 1. Schliff / piston w. ring 72,25 Ø, 1st oversize / pistone Ø 72,25 con segmento, 1a maggiorazione	1
	292 332	Kolben 72,5 Ø mit Ring, 2. Schliff / piston w. ring 72,5 Ø, 2nd oversize / pistone Ø 72,5 con segmento, 2a maggiorazione . . .	1
	292 333	Kolben 72,75 Ø mit Ring, 3. Schliff / piston w. ring 72,75 Ø, 3rd oversize / pistone Ø 72,75 con segmento, 3a maggiorazione	1
18	215 235	ETL-Ring 72,0 Ø, Standard / SEMI-trapez ring / segmento ETL	1
	215 231	ETL-Ring 72,25 Ø, 1. Schliff / SEMI-trapez ring / segmento ETL	1
	215 232	ETL-Ring 72,5 Ø, 2. Schliff / SEMI-trapez ring / segmento ETL	1
	215 233	ETL-Ring 72,75 Ø, 3. Schliff / SEMI-trapez ring / segmento ETL	1
19	916 185	Kolbenbolzen / piston pin / spinotto . . .	1
20	945 735	Nullhakenring 18 / circlip, piston pin / seger spinotto	2
21	230 552	Dichtung für Zylinderflansch / gasket, cylinder base / guarnizione cilindro . . .	1
22	213 726	Zylinder mit Büchse / cylinder with sleeve / cilindro con camicia	1
23	240 091	Stiftschraube M8 x 50 / stud / colonnetta .	6
24	831 790	O-Ring 78-2 / O-ring / anello gomma	1

Bild-Nr. Ill. No. Fig.	Teile-Nr. Part No. Codice	B e z e i c h n u n g D e s c r i p t i o n D e s c r i z i o n e	Stück Qty Qtà
25	230 200	O-Ring 142-3 / O-ring / anello gomma . .	1
26	213 740	Zylinderkopf / cylinder head / testa cilindro	1
27	250 311	Scheibe 8,4 / washer / rondella	6
28	842 326	Sechskantmutter M8 / hex. nut / dado . .	6
29	224 090	Ablaufrohr / tube / tubo	2
30	899 786	Schraubensicherungsmittel LOCTITE 242, blau / LOCTITE blue / LOCTITE blu . . .	nach Bedarf as required a richiesta
31	292 024	Kurbelwellen-Reparatursatz / crankshaft repair set / gruppo biella completa . .	1
32	213 730	Zylinderbüchse / cylinder sleeve / camicia cilindro	1

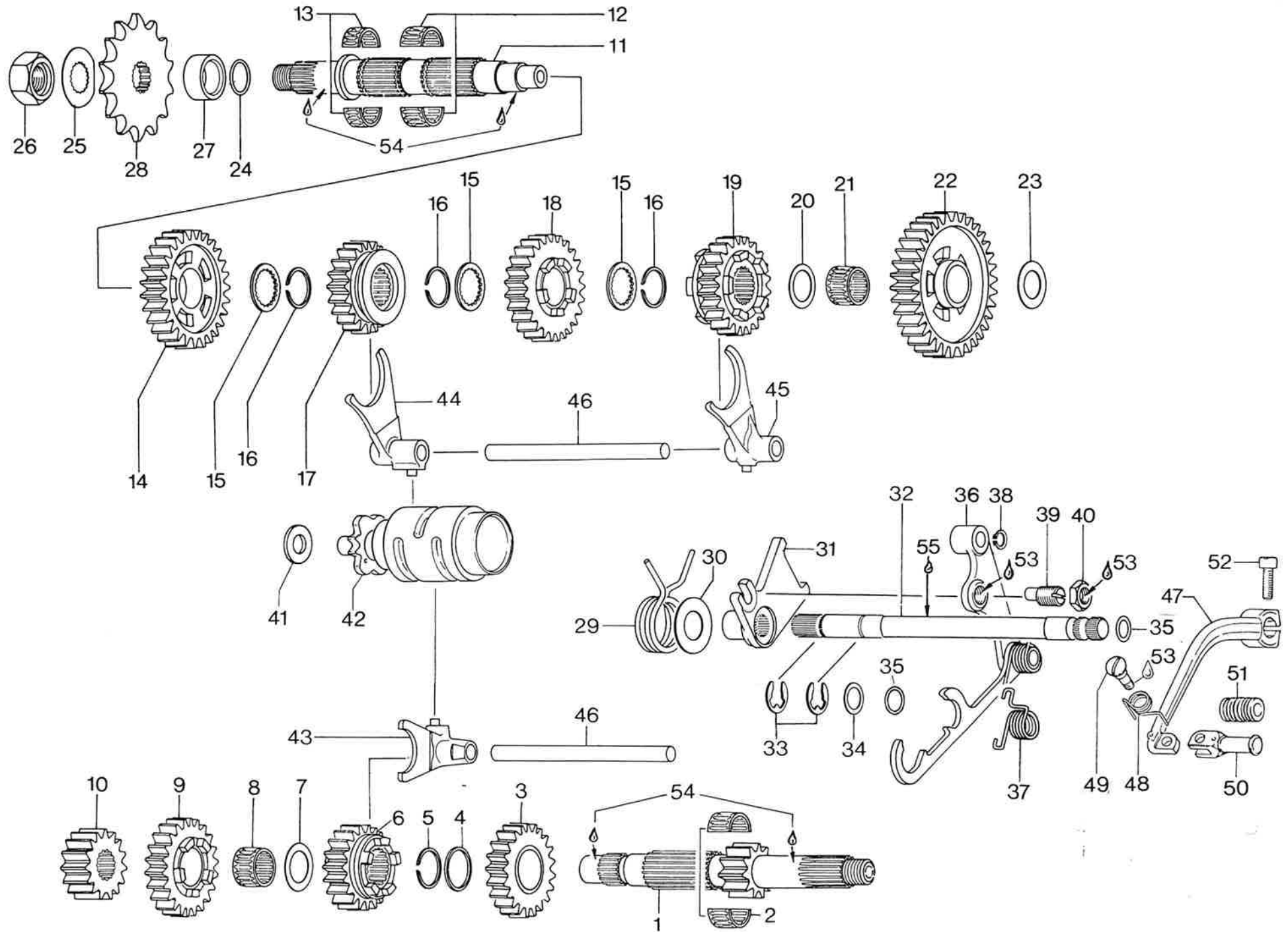

Getriebe
Transmission
Trasmissione

Bild-Nr. Ill. No. Fig.	Teile-Nr. Part No. Codice	B e z e i c h n u n g D e s c r i p t i o n D e s c r i z i o n e	Stück Qty Qtà
1 - 26	281 075	Getriebe kpl. / transmission assy. / cambio completo	1
1	237 560	Vorgelegewelle 13 Z. / clutch shaft / albero primario	1
2	232 795	Nadelkäfig / needle bearing / gabbia a rulli	1
3	235 620	Losrad 17 Z., ⁴ 4. Gang / gear 4th / ingranaggio 4 ^a	1
4	227 475	Anlaufscheibe 24,2x27,5x2,3 / thrust washer / spessore	1
5	245 340	Sprengring 24 / snapring / seger	1
6	235 602	Schaltrad 15 Z., 3. Gang / gear 3rd / ingranaggio 3 ^a	1
7	227 445	Anlaufscheibe 21,2x27,5x1 / thrust washer / spessore	1
8	232 805	Nadelkäfig / needle bearing / gabbia a rulli	1
9	235 660	Losrad 22 Z., ⁵ 5. Gang / gear 5th / ingranaggio 5 ^a	1
10	235 646	Festrad 13 Z., ² 2. Gang / gear 2nd / ingranaggio 2 ^a	1
11	237 454	Hauptwelle / main shaft / albero secondario	1
12	232 800	Nadelkäfig 21x25x13 / needle bearing / gabbia a rulli	1
13	232 740	Nadelkäfig 21x25x10 / needle bearing / gabbia a rulli	1
14	235 658	Losrad 23 Z., ² 2. Gang / gear 2nd / ingranaggio 2 ^a	1
15	227 465	Anlaufscheibe 22x30x2,6 / thrust washer / spessore	3
16	245 340	Sprengring 24 / snapring / seger	3

Bild-Nr. Ill. No. Fig.	Teile-Nr. Part No. Codice	B e z e i c h n u n g D e s c r i p t i o n D e s c r i z i o n e	Stück Qty Qtà
17	235 113	Schaltrad 21 Z., 5. Gang / gear 5th / ingranaggio 5 ^a	1
18	235 610	Losrad 21 Z., 3. Gang / gear 3rd / ingranaggio 3 ^a	1
19	235 633	Schaltrad 19 Z., 4. Gang / gear 4th / ingranaggio 4 ^a	1
20	944 468	Anlaufscheibe 20,5x30x1 / thrust washer / spessore	1
21	232 790	Nadelkäfig 20x24x12 / needle bearing / gabbia a rulli	1
22	235 473	Losrad 31 Z., 1. Gang / gear 1st / ingranaggio 1 ^a	1
23	227 430	Anlaufscheibe 17,2x30x1 / thrust washer / spessore	1
24	230 400	O-Ring 18-1,5 / O-ring / anello gomma . .	1
25	245 320	Sicherungsblech NA20 / washer / rondella .	1
26	242 605	Sechskantmutter M18 x 1,5 / hex. nut / dado	1
27	247 225	Distanzhülse 20x28x8,5 / distance sleeve / distanziale	1
28	236 950	Kettenrad 13 Z. / sprocket / pignone . . .	1
	236 951	Kettenrad 14 Z. / sprocket / pignone . . .	1
	236 952	Kettenrad 15 Z. / sprocket / pignone . . .	1
	236 953	Kettenrad 16 Z. / sprocket / pignone . . .	1
29	239 640	Haarnadelfeder / spring / molla	1
30	427 070	Scheibe 18,2x34x1 / thrust washer / spessore	1
31	258 575	Schwenkhebel / lever, transmission actuating / piastra portamolla cambio . .	1
32	237 437	Schaltwelle / shift shaft / albero cambio	1
33	945 790	Sicherungsscheibe 12 / retaining ring, shift shaft / seger albero cambio	2
34	944 851	Ausgleichscheibe 14,3/20/0,5 mm / shim 0,5 mm / spessore mm. 0,5	1
35	430 110	O-Ring 10-2,7 / O-ring / anello gomma . .	2

Bild-Nr. Ill. No. Fig.	Teile-Nr. Part No. Codice	B e z e i c h n u n g D e s c r i p t i o n D e s c r i z i o n e	Stück Qty Qtà
36	258 645	Schaltklinke / pawl assy. / grimagliera desmodromico	1
37	239 650	Klinkenfeder / spring, pawl / molla	1
38	245 330	Sicherungsring 10 x 1 / snapring / seger	1
39	241 805	Exzentrerschraube M12 x 1 / screw, pawl positioning / vite registro	1
40	242 270	Sechskantmutter M12 x 1 / hex. nut, pawl positioning locking / dado registro grimagliera	1
41	827 265	Scheibe 12,5/21,5/2 / washer / rondella	1
42	258 745	Schaltwalze kpl. / shift drum assy. / desmodromico	1
43	258 725	Schaltgabel 4./5. Gang / fork, shifting 4 - 5 / bandieretta cambio 4 ⁸ -5 ⁸	1
44	258 715	Schaltgabel 2. Gang / fork, shifting 2 / bandieretta cambio 2 ⁶	1
45	258 705	Schaltgabel 1./3. Gang / fork, shifting 1 - 3 / bandieretta cambio 1 ⁸ -3 ⁸	1
46	258 540	Schaltstange / pin, shift fork guide / asta bandieretta	2
47 - 51	248 917	Fußschalthebel kpl. / shift lever assy. / leva cambio completa	1
47	248 910	Fußschalthebel / shift lever / leva cambio	1
48	239 770	Hebelfeder / spring / molla	1
49	240 145	Lagerschraube M6 x 19 / bearing screw / vite	1
50	248 905	Klapphebel / folding lever / leva piegabile	1
51	260 545	Klapphebelschleife / rubber, folding lever / gommino leva piegabile	1
52	241 930	Zylinderschraube M6 x 20 / cyl. screw / vite	1
53	899 786	Schraubensicherungsmittel LOCTITE 242, blau / LOCTITE blue / LOCTITE blu	nach Bedarf as required a richiesta
54		Copa Slip	- " -
55		PB-Energrelase LS3	- " -

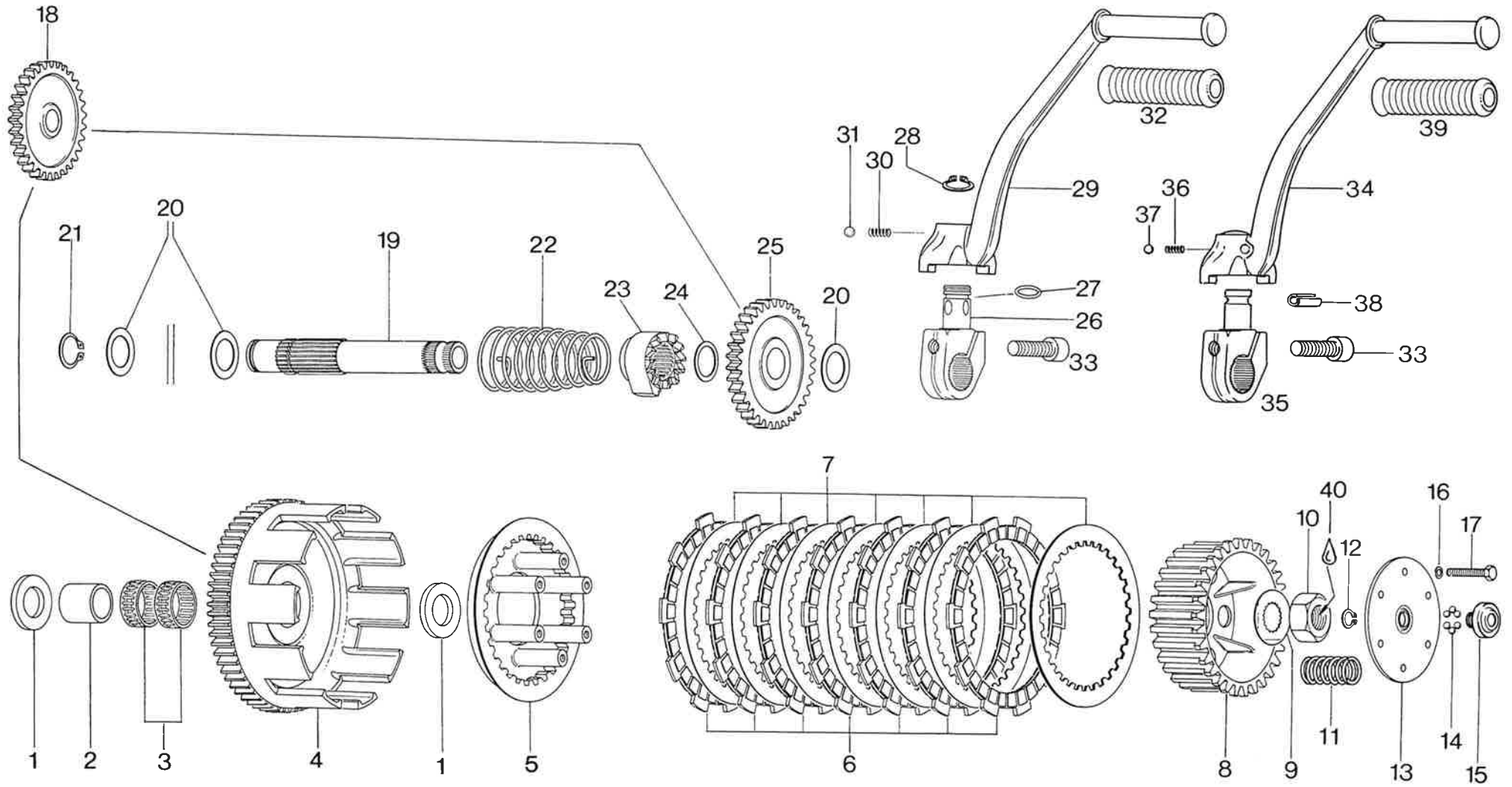

Kupplung, Kickstarter
Clutch, Kick Start
Frizione, Messa in Moto

Bild-Nr. Ill. No. Fig.	Teile-Nr. Part No. Codice	B e z e i c h n u n g D e s c r i p t i o n D e s c r i z i o n e	Stück Qty Qtà
1	227 600	Anlaufscheibe 20,2/35/3 / thrust washer, clutch drum / spessore campana frizione .	2
2	232 700	Innenring / inner race, clutch drum / boccola campana frizione	1
3	232 650	Nadelkäfig 25x29x10 / needle bearing, clutch drum / gabbia a rulli campana frizione	2
4	292 130	Primärtrieb kpl. (nur Antriebsrad mit Kupplungskorb gemeinsam austauschen!) / drive gear with clutch drum assy. (re- place only drive gear with clutch drum assy.!) / campana frizione (cambiare solo insieme ingranaggio con campana frizione!)	1
5	259 570	Stützteller / plate, clutch, inner pressure / tamburello	1
6	259 566	Belaglamelle 3 mm / plate, clutch friction / disco frizione guarnito . . .	7
7	259 557	Stahllamelle 1 mm / plate, clutch, outer pressure / disco frizione ferro . .	7
8	259 549	Mitnehmer / clutch hub / tamburello frizione	1
9	245 320	Sicherungsblech NA20 / washer, trans- mission shaft locking / rondella fissaggio dado frizione	1
10	242 605	Sechskantmutter M18 x 1,5 / hex. nut / dado frizione	1
11	239 740	Kupplungsfeder (Federn nur satzweise wechseln!) / spring, clutch (change springs only setwise!) / molla frizione (cambiare solo tutta la serie!)	6
12 - 15	259 596	Druckplatte kpl. / plate, clutch spring retaining with hub assy. / piattello completo frizione	1
12	245 330	Sicherungsring 10 x 1 / snapring / seger piattello frizione	1

Bild-Nr. Ill. No. Fig.	Teile-Nr. Part No. Codice	B e z e i c h n u n g D e s c r i p t i o n D e s c r i z i o n e	Stück Qty Qtà
13	259 590	Druckplatte / plate, clutch spring retaining / piattello	1
14	932 990	Kugel 5/32" / ball / sfere piattello . .	12
15	259 705	Druckpilz / hub, clutch spring retaining / cuscinetto piattello	1
16	945 750	Federring A5 / locking washer 5 / rondella grower 5, fissaggio piattello frizione	6
17	241 770	Sechskantschraube M5 x 25 / screw, hex. head / vite fissaggio piattello frizione	6
18	235 205	Zwischenrad kpl. / gear, kick start idler / ingranaggio intermedio messa in moto	1
19	237 428	Starterwelle / kick start shaft / albero messa in moto	1
20	944 468	Anlaufscheibe 20,5/30/1 / thrust washer / spessore messa in moto	3
21	945 660	Sicherungsring 20 x 1,2 / snapring, kick start shaft / seger messa in moto	1
22	239 760	Kickstarterfeder / spring, kick start return / molla di richiamo messa in moto	1
23	228 185	Sperrad / ratchet gear, kick start / innesto messa in moto	1
24	227 480	Anlaufscheibe 20,2/25,5/1 / thrust washer, kick gear / spessore albero messa in moto	1
25	235 215	Starterrad kpl. / gear, kick start drive / ingranaggio messa in moto	1
26 - 32	248 870	Kickstarterhebel kpl. / lever assy., kick start / pedale messa in moto	1
26 - 28	248 809	Kickstarternabe kpl. / hub assy., kick start / parte inferiore messa in moto . .	1
27	230 461	O-Ring 8,9-1,9 / O-ring / anello snodo messa in moto	1
28	945 845	Sicherungsring 15 x 1,5 / snapring, kick start lever / seger messa in moto	1
29	248 794	Kickstarterhebel / lever, kick start / parte superiore messa in moto	1

Bild-Nr. Ill. No. Fig.	Teile-Nr. Part No. Codice	B e z e i c h n u n g D e s c r i p t i o n D e s c r i z i o n e	Stück Qty Qtà
30	239 535	Druckfeder / spring, kick start lever / molla sfera messa in moto	1
31	232 440	Kugel 7/32" / ball, kick start lever / sfera messa in moto	1
32	260 210	Muffe / rubber sleeve, kick start / gommino pedale messa in moto	1
33	840 991	Zylinderschraube M8 x 30 / cyl. screw / vite fissaggio messa in moto	1
34 - 39	248 020	Kickstarterhebel kpl. (geschlossene Ausführung) / lever assy., kick start (closed execution) / pedale messa in moto (esecuzione chiusa) compl.	1
34	248 015	Kickstarterhebel (geschlossene Aus- führung) / lever, kick start (closed execution) / pedale messa in moto (esecuzione chiusa)	1
35	248 980	Kickstarternabe / hub, kick start / parte inferiore messa in moto	1
36	239 537	Druckfeder / spring, kick start lever / molla sfera messa in moto	1
37	232 440	Kugel 7/32" / ball, kick start lever / sfera messa in moto	1
38	229 210	Spannhülse 6 x 20 / dowel tube / perno tenditore	1
39	260 210	Muffe / rubber sleeve, kick start / gommino pedale messa in moto	1
40	899 786	Schraubensicherungsmittel 6 ccm, LOCTITE 242, blau / means of securing, LOCTITE blue, 6 c.c. / flacone LOCTITE blu 6 cc.	nach Bedarf as required a richiesta

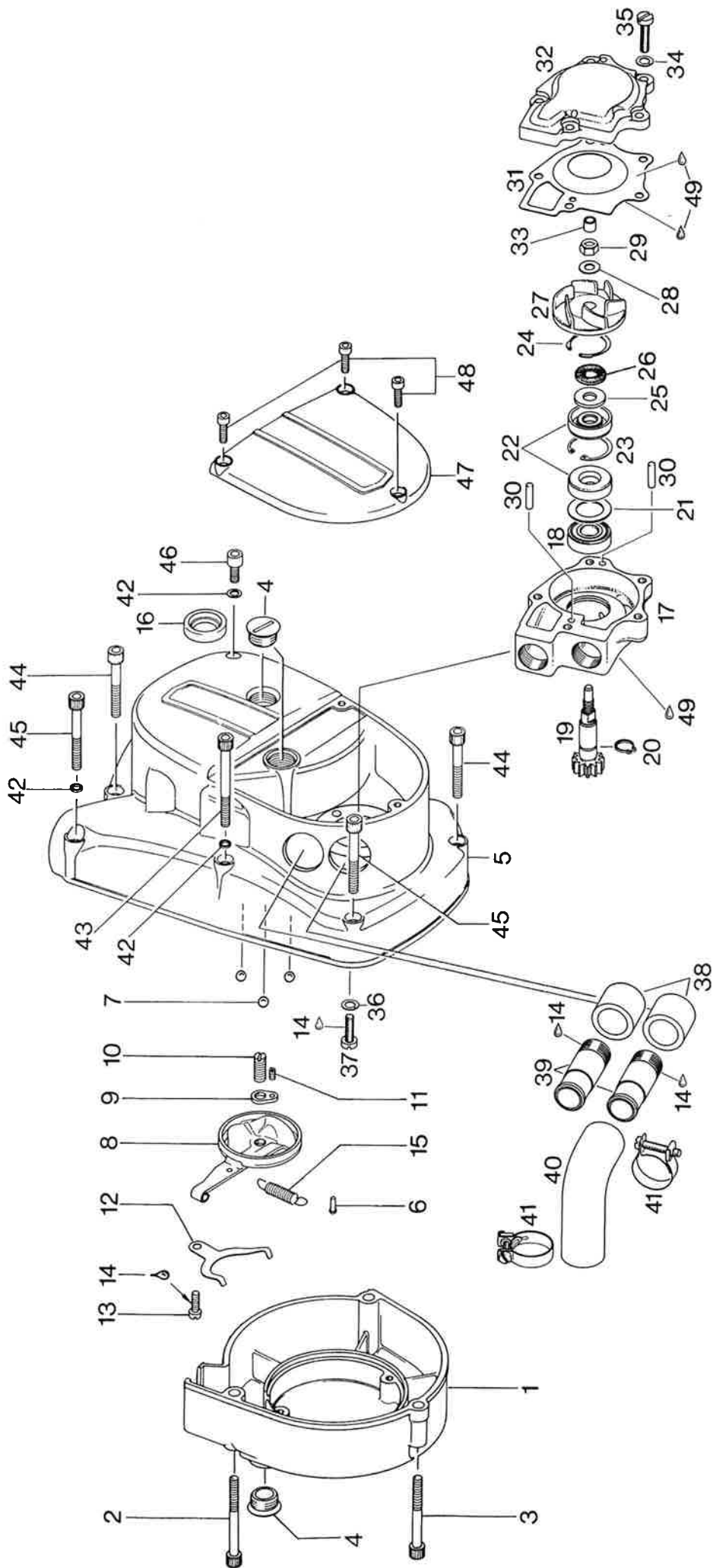
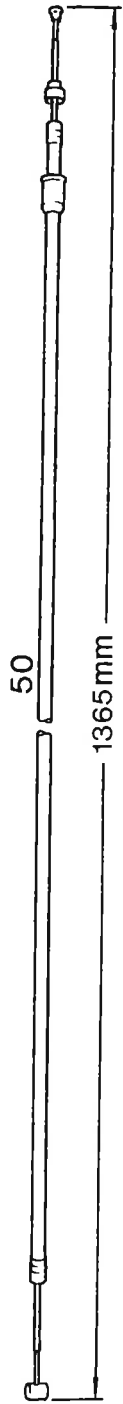

Zünderdeckel, Kupplungsdeckel, Wasserpumpe, Kupplungsausrücker mit 7/32" Kugeln
 Magneto Cover, Clutch Cover, Water Pump, Cam assy. with 7/32" balls
 Coperchio Volano, Coperchio Frizione, Pompa Acqua, Chiocciola con Sfere 7/32"

Bild-Nr. Ill. No. Fig.	Teile-Nr. Part No. Codice	B e z e i c h n u n g D e s c r i p t i o n D e s c r i z i o n e	Stück Qty Qtà
1	212 151	Zünderdeckel / magneto cover / coperchio volano	1
2	241 761	Zylinderschraube M6 x 50 / cyl. screw / vite	2
3	241 821	Zylinderschraube M6 x 45 / cyl. screw / vite	1
4	241 800	Verschlußschraube M18 x 1,5 / plug screw / vite tappo	3
5,6,	212 798	Kupplungsdeckel kpl. / clutch cover assy. / coperchio frizione completo . . .	1
6	949 030	Halbrundkerbnagel 3 x 8 / drive pin / spina	1
7	232 440	Kugel 7/32" / ball / sfera	3
8	259 790	Ausrückteller kpl. / cam assy., clutch release / chiocciola frizione	1
9	259 630	Fixierplatte / plate, clutch adjustment locking / fermo vite registro frizione . .	1
10	241 791	Gewindestift M8 x 16 / screw, clutch adjustment / vite registro frizione . . .	1
11	241 795	Gewindestift M4 x 6 / screw / grano fermo	1
12	239 660	Blattfeder / spring, clutch cam retaining / innesto frizione	1
13	240 560	Zylinderschraube M5 x 12 / cyl. screw / vite	1
14	899 786	Schraubensicherungsmittel LOCTITE 242, blau / LOCTITE blue / LOCTITE blu	nach Bedarf as required a richiesta
15	239 630	Zugfeder / spring, clutch cam return / molla	1
16	230 355	Wellendichtring BS 20x28x6 / oil seal / corteco	1
17 - 35	293 265	Wasserpumpe kpl. / water pump assy. / pompa acqua completa	1

Bild-Nr. Ill. No. Fig.	Teile-Nr. Part No. Codice	B e z e i c h n u n g D e s c r i p t i o n D e s c r i z i o n e	Stück Qty Qtà
17	222 070	Wasserpumpengehäuse / housing, water pump / corpo pompa acqua	1
18	232 100	Rillenkugellager 6000 / ball bearing / cuscinetto	1
19	237 750	Pumpenwelle 11 Z. / pump shaft 11 t. / albero pompa 11 d.	1
20	245 330	Sicherungsring 10 x 1 / snapring / seger .	1
21	227 480	Scheibe 20,2x25,5x1 / shim 1,0 mm / spessore	1
22	230 190	Wellendichtring 10x26x7 / oil seal / corteco	2
23	245 560	Sicherungsring 24 x 1,2 / snapring / seger	1
24	245 555	Sicherungsring 26 x 1,2 / snapring / seger	1
25	239 930	Tellerfeder A16 / spring washer 16 / rondella grower 16	1
26	227 155	Reibscheibe / friction washer / ranella . .	1
27	922 035	Lauftrad / impeller, water pump / girante .	1
28	244 211	Scheibe 6,4 / washer / rondella	1
29	842 040	Sicherungsmutter M6 / lock nut / dado . . .	1
30	232 730	Nadelrolle 4x15,8 G3 / needle roll / perno	2
31	222 090	Leitblech / guiding plate / lamiera di guida	1
32,33,	222 081	Wasserpumpendeckel kpl. / cover assy., water pump / coperchio completo, pompa acqua	1
33	233 520	Lagerbüchse / bushing / bussola	1
34	945 750	Federring A5 / lock washer / rondella grower	5
35	840 351	Zylinderschraube M5 x 20 / cyl. screw / vite	5
36	945 750	Federring A5 / lock washer / rondella grower	3
37	240 761	Zylinderschraube M5 x 16 / cyl. screw / vite	3

Bild-Nr. Ill. No. Fig.	Teile-Nr. Part No. Codice	B e z e i c h n u n g D e s c r i p t i o n D e s c r i z i o n e	Stück Qty Qtà
38	222 105	Dichtschauch / sealing tube / tubo guarnizione	2
39	224 095	Zulaufrohr / tube / tubo	2
40	222 100	Kühlwasserschlauch / water tube / tubo acqua	1
41	251 870	Schlauchselle 23 kpl. / hose clamp assy. / fascetta manicotto tubo	2
42	830 890	Dichtring 6,2/8,9/1 / gasket ring / rondella guarnizione	3
43	241 761	Zylinderschraube M6 x 50 / cyl. screw / vite	1
44	241 811	Zylinderschraube M6 x 35 / cyl. screw / vite	5
45	241 816	Zylinderschraube M6 x 40 / cyl. screw / vite	3
46	840 371	Zylinderschraube M6 x 11,5 / cyl. screw, oil level / vite	1
47	212 066	Pumpendeckel / pump cover / coperchio pompa	1
48	241 841	Zylinderschraube M5 x 12 / cyl. screw / vite	3
49		SILASTIC	nach Bedarf as required a richiesta
50	297 445	Kupplungsseilzug kpl. / clutch cable assy. / cavo frizione completo	1

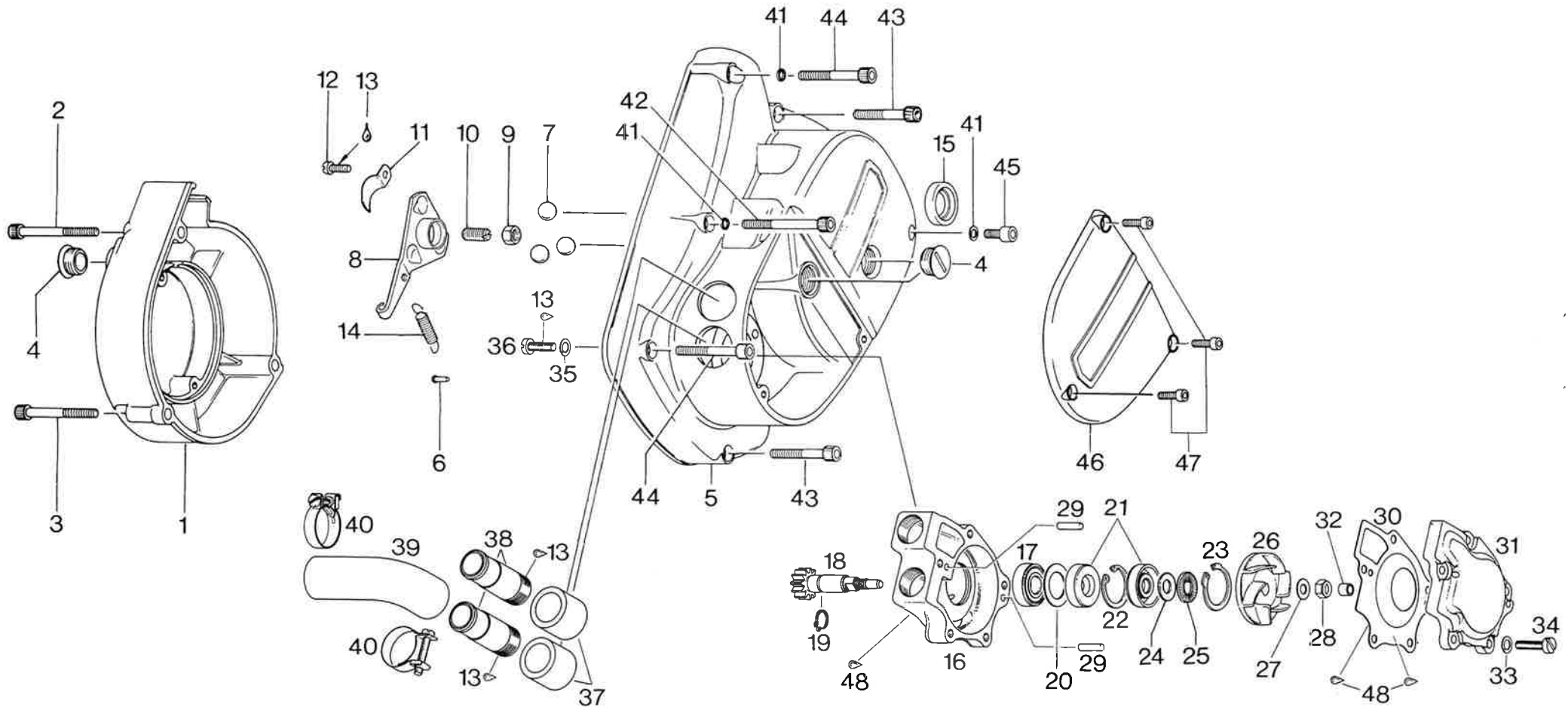
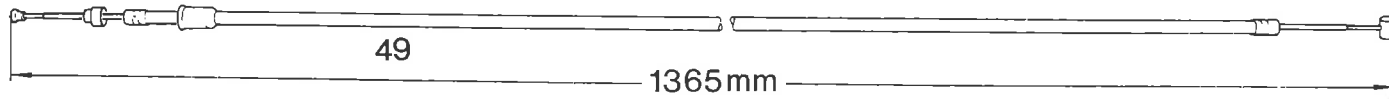

Zünderdeckel, Kupplungsdeckel, Wasserpumpe, Kupplungsausrücker mit 12 mm Kugeln
 Magneto Cover, Clutch Cover, Water Pump, Cam assy. with 12 mm balls
 Coperchio Volano, Coperchio Frizione, Pompa Acqua, Chiocciola con Sfere 12 mm

Bild-Nr. Ill. No. Fig.	Teile-Nr. Part No. Codice	B e z e i c h n u n g D e s c r i p t i o n D e s c r i z i o n e	Stück Qty Qtà
1	212 151	Zünderdeckel / magneto cover / coperchio volano	1
2	241 761	Zylinderschraube M6 x 50 / cyl. screw / vite	2
3	241 821	Zylinderschraube M6 x 45 / cyl. screw / vite	1
4	241 800	Verschlußschraube M18 x 1,5 / plug screw / vite tappo	3
5,6,	210 018	Kupplungsdeckel kpl. / clutch cover assy. / coperchio frizione completo . . .	1
6	949 030	Halbrundkerbnagel 3 x 8 / drive pin / spina	1
7	232 150	Kugel 12 mm / ball / sfera	3
8	259 945	Ausrückteller kpl. / cam assy., clutch release / chiocciola frizione	1
9	942 670	Sechskantmutter M8 / hex. nut / dado . . .	1
10	241 791	Gewindestift M8 x 16 / screw, clutch adjustment / vite registro frizione . . .	1
11	239 901	Blattfeder / spring, clutch cam retaining / innesto frizione	1
12	240 560	Zylinderschraube M5 x 12 / cyl. screw / vite	1
13	899 786	Schraubensicherungsmittel LOCTITE 242, blau / LOCTITE blue / LOCTITE blu	nach Bedarf as required a richiesta
14	239 635	Zugfeder / spring, clutch cam return / molla	1
15	230 355	Wellendichtring BS 20x28x6 / oil seal / corteco	1
16 - 34	293 265	Wasserpumpe kpl. / water pump assy. / pompa acqua completa	1
16	222 070	Wasserpumpengehäuse / housing, water pump / corpo pompa acqua	1

Bild-Nr. Ill. No. Fig.	Teile-Nr. Part No. Codice	B e z e i c h n u n g D e s c r i p t i o n D e s c r i z i o n e	Stück Qty Qtà
17	232 100	Rillenkugellager 6000 / ball bearing / cuscinetto	1
18	237 750	Pumpenwelle 11 Z. / pump shaft 11 t. / albero pompa 11 d.	1
19	245 330	Sicherungsring 10 x 1 / snapring / seger .	1
20	227 480	Scheibe 20,2x25,5x1 / shim 1,0 mm / spessore	1
21	230 190	Wellendichtring 10x26x7 / oil seal / corteco	2
22	245 560	Sicherungsring 24 x 1,2 / snapring / seger	1
23	245 555	Sicherungsring 26 x 1,2 / snapring / seger	1
24	239 930	Tellerfeder A16 / spring washer 16 / rondella grower 16	1
25	227 155	Reibscheibe / friction washer / ranella .	1
26	922 035	Lauftrad / impeller, water pump / girante .	1
27	244 211	Scheibe 6,4 / washer / rondella	1
28	842 040	Sicherungsmutter M6 / lock nut / dado . .	1
29	232 730	Nadelrolle 4x15,8 G3 / needle roll / perno	2
30	222 090	Leitblech / guiding plate / lamiera di guida	1
31,32,	222 081	Wasserpumpendeckel kpl. / cover assy., water pump / coperchio completo, pompa acqua	1
32	233 520	Lagerbüchse / bushing / bussola	1
33	945 750	Federring A5 / lock washer / ronella grower	5
34	840 351	Zylinderschraube M5 x 20 / cyl. screw / vite	5
35	945 750	Federring A5 / lock washer / ronella grower	3
36	240 761	Zylinderschraube M5 x 16 / cyl. screw / vite	3
37	222 105	Dichtschlauch / sealing tube / tubo guarnizione	2

Bild-Nr.. Ill. No. Fig.	Teile-Nr. Part No. Codice	B e z e i c h n u n g D e s c r i p t i o n D e s c r i z i o n e	Stück Qty Qtà
38	224 095	Zulaufrohr / tube / tubo	2
39	222 100	Kühlwasserschlauch / water tube / tubo acqua	1
40	251 870	Schlauchschele 23 kpl. / hose clamp assy. / fascetta manicotto tubo	2
41	830 890	Dichtring 6,2/8,9/1 / gasket ring / rondella guarnizione	3
42	241 761	Zylinderschraube M6 x 50 / cyl. screw / vite	1
43	241 811	Zylinderschraube M6 x 35 / cyl. screw / vite	5
44	241 816	Zylinderschraube M6 x 40 / cyl. screw / vite	3
45	840 371	Zylinderschraube M6 x 11,5 / cyl. screw, oil level / vite	1
46	212 066	Pumpendeckel / pump cover / coperchio pompa	1
47	241 841	Zylinderschraube M5 x 12 / cyl. screw / vite	3
48		SILASTIC	nach Bedarf as required a richiesta
49	297 445	Kupplungsseilzug kpl. / clutch cable assy. / cavo frizione completo	1

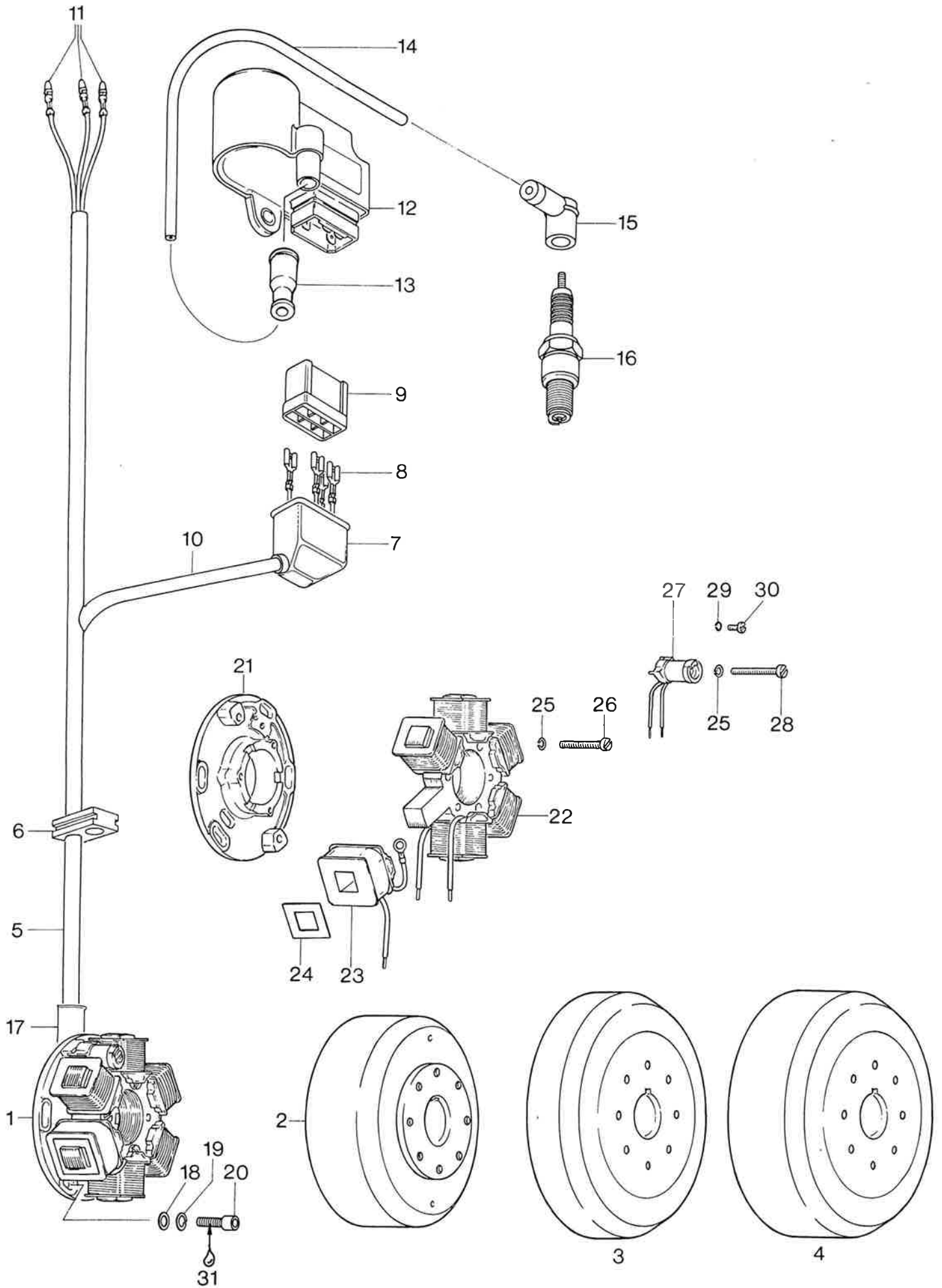

Magnetzünder-Generator 12V 60W
 Magneto-Generator 12V 60W
 Volano 12V 60W

Bild-Nr. Ill. No. Fig.	Teile-Nr. Part No. Codice	B e z e i c h n u n g D e s c r i p t i o n D e s c r i z i o n e	Stück Qty Qtà
1,2,5 - 15	292 344	MZ-Generator kpl. (Ausführung mit leichtem Schwungrad) / magneto generator assy. (execution with light flywheel) / volano completo (esecuzione con volano leggero) .	1
1,3,5 - 15	292 345	MZ-Generator kpl. (Ausführung mit mittelschwerem Schwungrad) / magneto generator assy. (execution with medium weight flywheel) / volano completo (esecuzione con volano medio)	1
1,4,5 - 15	292 229	MZ-Generator kpl. (Ausführung mit schwerem Schwungrad) / magneto generator assy. (execution with heavy flywheel) / volano completo (esecuzione con volano pesante) .	1
1,5 - 11	292 232	Ankerplatte kpl. / stator plate assy. / piatto volano completo	1
2	292 274	Magnetrad kpl. (leicht) / flywheel assy. (light) / parte rotante volano (leggero) .	1
3	292 277	Magnetrad kpl. (mittelschwer) / flywheel assy. (medium weight) / parte rotante volano (medio)	1
4	292 276	Magnetrad kpl. (schwer) / flywheel assy. (heavy) / parte rotante volano (pesante) .	1
5	260 435	Isolierschlauch 600 mm / protection hose / guaina impianto	1
6	260 345	Leitungstülle / cable grommet / gommina filo volano	1
7	960 791	Schutzkappe / protection cap / cuffia centralina	1
8	864 011	Steckhülse / Faston connector / spinetta Faston	4
9	865 453	Steckergehäuse / connector housing / guaina	1
10	260 467	Isolierschlauch 285 mm / protection hose / guaina impianto	1
11	964 062	Steckerstift / contact pin / spina a baionetta	3

Bild-Nr. Ill. No. Fig.	Teile-Nr. Part No. Codice	B e z e i c h n u n g D e s c r i p t i o n D e s c r i z i o n e	Stück Qty Qtà
12	264 475	Elektronikbox / electronic box / centralina	1
13	960 550	Regenschutzkappe / protection cap / cappuccio gomma filo candela	1
14	864 075	Zündleitung 440 mm / ignition cable / filo candela	1
15	865 200	Zündleistungsstecker / spark plug protector / cappuccio candela	1
16	899 576	Zündkerze W300 T2 / spark plug W300 T2 / candela W300 T2	1
17	224 030	Kabelfixierung / holder, cables / impianto	1
18	927 570	Scheibe 5,3 / washer / rondella	2
19	945 750	Federring A5 / lock washer / rondella grower	2
20	840 510	Zylinderschraube M5 x 16 / cyl. screw / vite	2
21	866 245	Ankerplatte / stator plate alone / piatto nudo volano	1
22,23,24,	264 675	Ankersatz kpl. / coil set with iron core assy. / gruppo bobine	1
23	866 230	Ladeanker / charging coil / bobina alimentazione	1
24	264 680	Kurzschlußplatte / damping plate / piatto ammortizzatore	1
25	945 758	Federring A4 / lock washer / rondella grower	4
26	941 281	Zylinderschraube M4 x 25 / cyl. screw / vite	3
27	264 665	Steueranker / trigger coil / bobina commando	1
28	241 327	Zylinderschraube M4 x 28 / cyl. screw / vite	1
29	245 090	Federring A3 / lock washer / rondella grower	1
30	941 205	Zylinderschraube M3 x 6 / cyl. screw / vite	1
31	899 786	Schraubensicherungsmittel LOCTITE 242, blau / LOCTITE blue / LOCTITE blu	nach Bedarf as required a richiesta

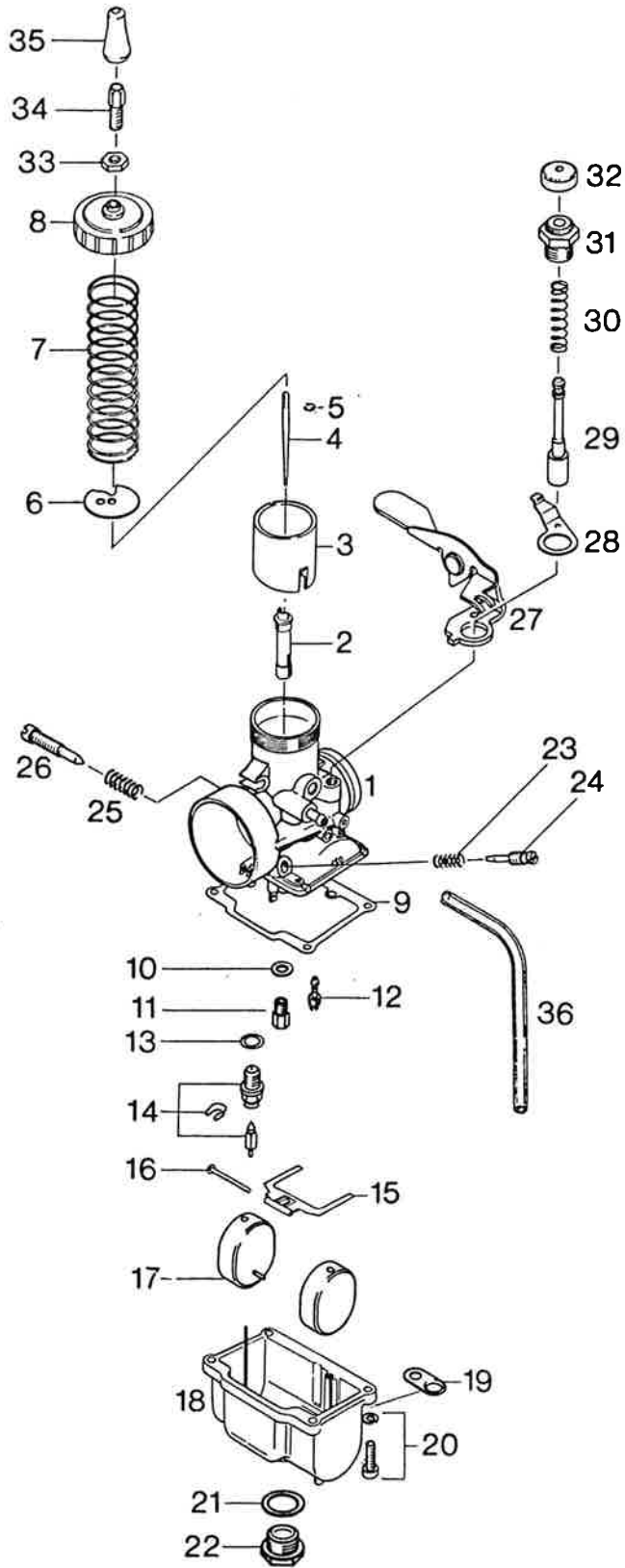

MIKUNI-Vergaser
MIKUNI-Carburetor
Carburatore MIKUNI

Bild-Nr. Ill. No. Fig.	Teile-Nr. Part No. Codice	B e z e i c h n u n g D e s c r i p t i o n D e s c r i z i o n e	Stück Qty Qtà
1 - 34	291 948	MIKUNI-Vergaser VM34-253 / MIKUNI-carburetor assy. / carburatore MIKUNI . .	1
1		Vergasergehäuse kpl. (nicht als Ersatzteil lieferbar, Vergaser kpl. muß verwendet werden) / carburetor housing (not available as spare part, use carburetor assy.) / corpo carburatore (non fornibile come pezzo di ricambi, bisogna usare carburatore completo) . . .	1
2	963 956	Nadeldüse 159/P-8 / needle jet / pulverizzatore	1
3	963 937	Gasschieber / carburetor piston / valvola gas	1
4	963 923	Düsennadel / jet needle / spillo valvola	1
5	845 230	Sicherungsscheibe / circlip / seger . . .	1
6	963 940	Federplatte / retainer plate / ranella molla valvola gas	1
7	938 930	Schieberfeder / spring, carburetor piston / molla valvola gas	1
8	963 875	Deckelverschraubung / threaded cap / coperchio valvola	1
9	831 895	Dichtung / gasket / guarnizione	1
10	827 660	Scheibe 5,3 / washer / rondella	1
11	963 880	Hauptdüse 270 / main jet / getto	1
	963 976	Hauptdüse 260 / main jet / getto	1
	963 881	Hauptdüse 280 / main jet / getto	
	963 882	Hauptdüse 290 / main jet / getto	
	963 883	Hauptdüse 300 / main jet / getto	
	963 884	Hauptdüse 310 / main jet / getto	
12	963 820	Leerlaufdüse 35 / idler jet / getto minimo	1

Bild-Nr. Ill. No. Fig.	Teile-Nr. Part No. Codice	B e z e i c h n u n g D e s c r i p t i o n D e s c r i z i o n e	Stück Qty Qtà
	963 825	Leerlaufdüse 40 / idler jet / getto minimo	
13	831 905	Dichtring / sealing ring / anello guarnizione	1
14	963 847	Nadelventil kpl. / needle valve assy. / valvola a spillo	1
15	963 835	Schwimmernadel / float arm / leva galleggiante	1
16	929 770	Stift / pin, float arm / perno leva galleggiante	1
17	963 905	Schwimmer / float / galleggiante	2
18		Schwimmergehäuse (nicht als Ersatzteil lieferbar) / float chamber (not available as spare part) / vaschetta (non fornibile come pezzo di ricambi)	1
19	261 800	Schlauchlasche / plate / coprigiunto . . .	2
20	240 450	Kombischraube M5 x 16 / combined screw / vite	4
21	230 900	Dichtring / sealing ring / anello guarnizione	1
22	963 967	Ablaßschraube / plug screw / vite	1
23	938 950	Druckfeder / spring, air regulating screw / molla vite aria	1
24	963 860	Luftregulierschraube / air regulating screw / vite aria	1
25	938 940	Druckfeder / spring, adjustment screw / molla vite minimo	1
26	963 850	Stellschraube / adjustment screw / vite minimo	1
27	261 810	Handhebel kpl. / choke lever assy. / dispositivo starter completo	1
28	239 840	Blattfeder / spring / molla ballestra . .	1
29	963 795	Startkolben mit Dichtung / starting piston with gasket / pistoncino starter con guarnizione	1
30	938 925	Druckfeder / spring, starting piston / molla pistoncino starter	1

Bild-Nr. Ill. No. Fig.	Teile-Nr. Part No. Codice	B e z e i c h n u n g D e s c r i p t i o n D e s c r i z i o n e	Stück Qty Qtà
31	963 817	Startgehäuse / housing, starting piston / corpo pistoncino starter	1
32	260 495	Gummikappe / rubber cap / gommino tappo corpo pistoncino aria	1
33	942 541	Sechskantmutter M6 x 0,75 / hex. nut / dado registro filo gas	1
34	241 445	Stellschraube M6 x 0,75 / adjustment screw / registro filo gas	1
35	960 980	Gummitülle / rubber grommet / cappuccio registro filo gas	1
36	260 581	Entlüfterschlauch 120 mm / vent line / tubo dell'aria	2

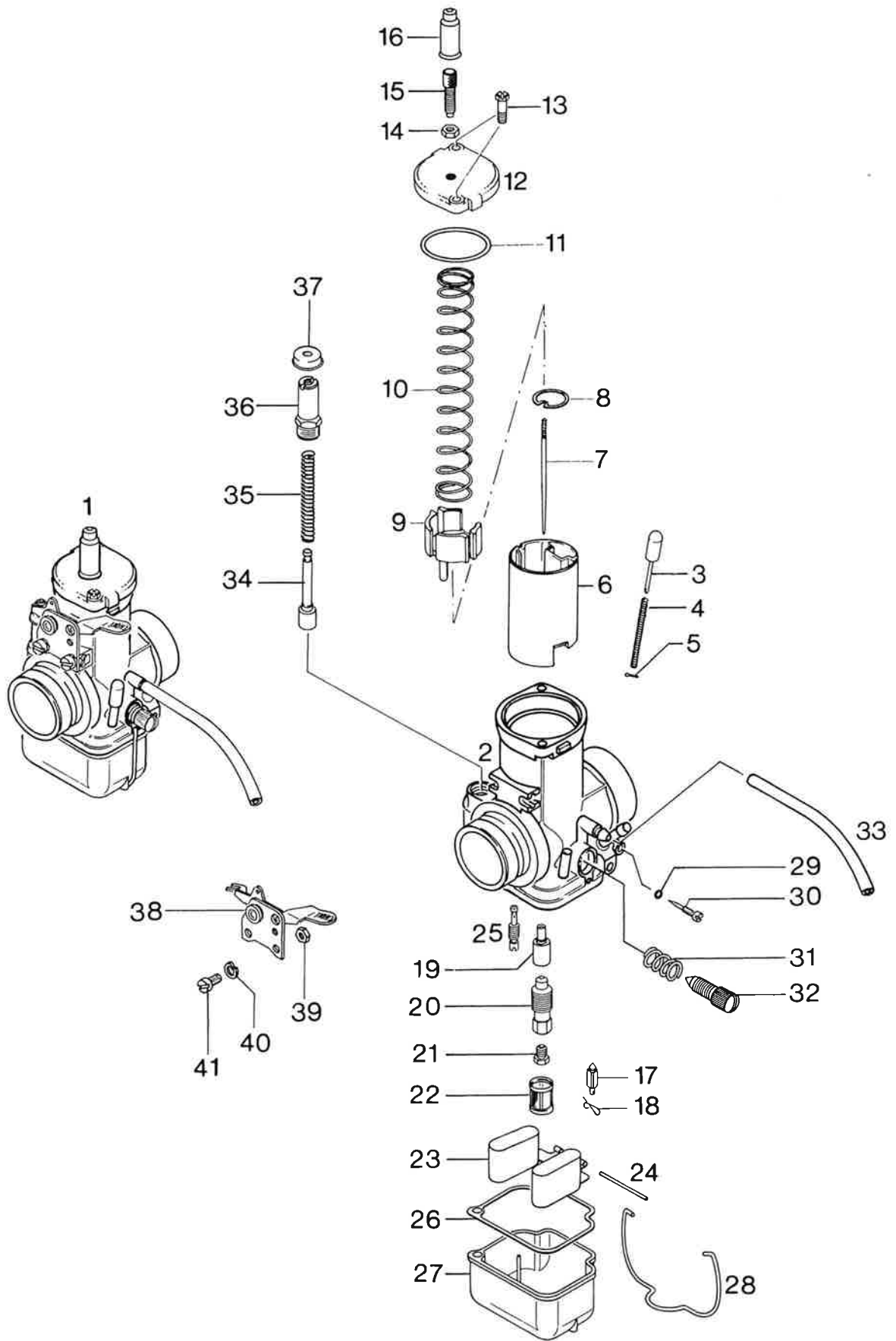

BING-Vergaser
 BING-Carburetor
 Carburatore BING

Bild-Nr. Ill. No. Fig.	Teile-Nr. Part No. Codice	B e z e i c h n u n g D e s c r i p t i o n D e s c r i z i o n e	Stück Qty Qtà
1	292 811	DS-Startvergaser 54/34/118 / carburetor / carburatore	1
2		Vergasergehäuse kpl. (nicht als Ersatz- teile lieferbar, Vergaser kpl. muß ver- wendet werden / carburetor housing assy. (not available as spare part, use carburetor assy.) / corpo carburatore completo (non fornibile come pezzo di ricambi, bisogna usare carburatore completo)	1
3	963 780	Tupfer / tickler / titillatore	1
4	938 910	Tupferfeder / spring, tickler / molla titillatore	1
5	261 090	Splin 0,8 x 5 / splint pin / coppiglia .	1
6	963 674	Gasschieber / carburetor piston / valvola gas	1
7	963 716	Düsennadel 4E2 / jet needle / spillo valvola	1
8	963 500	Halteplättchen / holding plate / piatto .	1
9	827 345	Federtasse / plastic spring cup / custodia molla valvola gas	1
10	938 765	Schieberfeder 1,1/14 / spring, carburetor piston / molla valvola gas	1
11	831 450	Gummidichtung / rubber ring / anello gomma	1
12	963 720	Deckelplatte / cover plate / coperchio .	1
13	241 430	Sechskantschraube M5 x 12 / screw, hex. head / vite	2
14	942 541	Sechskantmutter M6 x 0,75 / hex. nut / dado	1
15	241 440	Stellschraube M6 x 0,75 / adjustment screw / vite registro	1
16	260 370	Gummitülle / rubber grommet / cappuccio gomma	1

Bild-Nr. Ill. No. Fig.	Teile-Nr. Part No. Codice	B e z e i c h n u n g D e s c r i p t i o n D e s c r i z i o n e	Stück Qty Qtà
17	261 705	Schwimmernadel / float needle / spillo galleggiante	1
18	261 710	Klemmbügel / clip, float needle / fermo spillo galleggiante	1
19	961 020	Nadeldüse 2,86 / needle jet / getto ad ago	1
20	261 140	Düsenstock / mixing tube / porta getto . .	1
21	268 985	Hauptdüse 160 / main jet / getto	1
22	261 625	Siebhülse / sieve sleeve / filtro getto .	1
23	963 192	Schwimmer / float / galleggiante	1
24	929 700	Stift / pin, float needle / perno spillo galleggiante	1
25	963 140	Leerlaufdüse 50 / idler jet / getto minimo	1
26	830 720	Dichtung / gasket, float chamber / guarnizione	1
27	261 617	Schwimmergehäuse / float chamber / vaschetta	1
28	963 180	Federbügel / spring clip / archetto molla	1
29	831 710	O-Ring 3,2-1,8 / O-ring / anello gomma . .	1
30	963 155	Luftregulierschraube / air regulating screw / vite aria	1
31	938 640	Feder / spring, adjustment screw / molla vite registro	1
32	963 160	Stellschraube / adjustment screw / vite registro	1
33	256 035	Belüftungsschlauch 120 mm / vent line / tubo sfiatto	2
34	268 847	Startkolben mit Dichtung / starting piston with gasket / pistoncino starter con guarnizione	1
35	239 730	Druckfeder / spring, starting piston / molla pistoncino starter	1
36	261 770	Startgehäuse / housing, starting piston / guida pistoncino	1
37	260 490	Gummikappe / rubber cap / gommino tappo guida pistoncino	1

Bild-Nr. Ill. No. Fig.	Teile-Nr. Part No. Codice	B e z e i c h n u n g D e s c r i p t i o n D e s c r i z i o n e	Stück Qty Qtà
38	261 755	Handhebel kpl. / choke lever assy. / dispositivo starter completo	1
39	261 200	Sechskantmutter M5 / hex. nut / dado . . .	2
40	945 750	Federring A5 / lock washer / rondella grower	2
41	240 791	Zylinderschraube M5 x 10 / syl. screw / vite	2

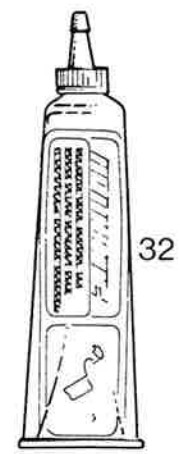
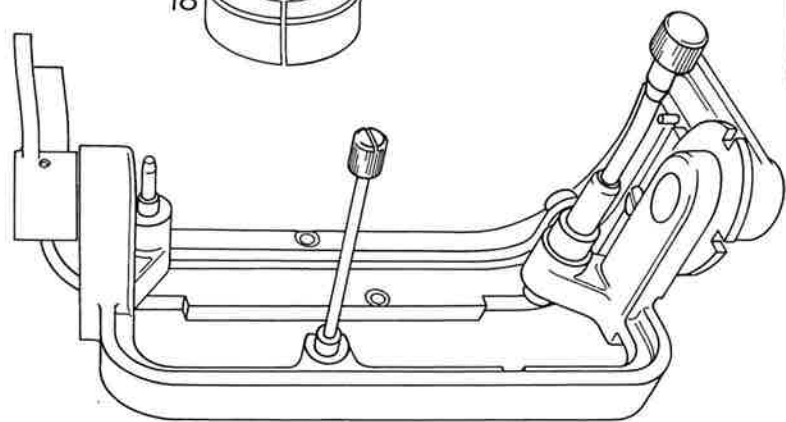
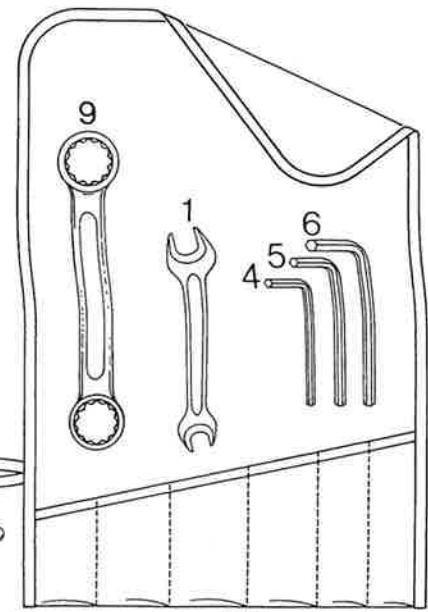
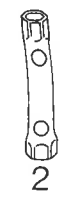
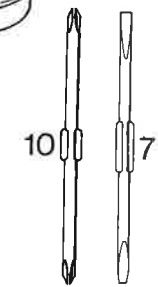
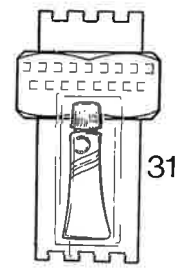
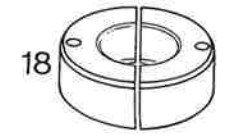
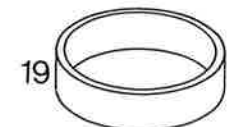
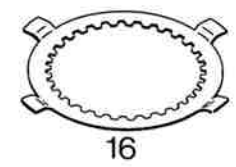
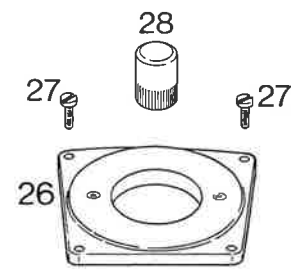
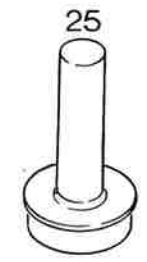
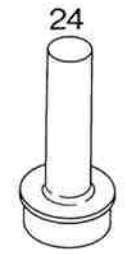
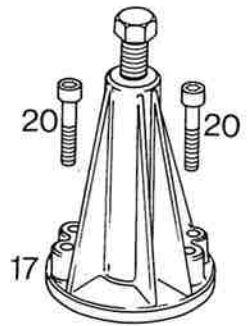
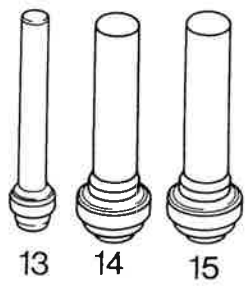

Werkzeug / Tools / Attrezzi

Bild-Nr. Ill. No. Fig.	Teile-Nr. Part No. Codice	B e z e i c h n u n g D e s c r i p t i o n D e s c r i z i o n e	Stück Qty Qtà
1 - 10	277 780	Werkzeugsatz kpl. / tool kit, owners / truss ferri	1
1 - 12	277 784	Werkzeugsatz kpl. / tool kit, owners / truss ferri	1
1	276 065	Doppelmaulschlüssel 10x13 mm / fork wrench / chiave fissa	1
2	876 220	Steckschlüssel 11x13 mm / socket wrench / chiave a tubo	1
3	277 411	Steckschlüssel 17x21 mm / socket wrench / chiave a tubo	1
4	277 790	Sechskant-Stiftschlüssel 4 / wrench, int. hex. screw / chiave a brugola . . .	1
5	876 360	Sechskant-Stiftschlüssel 5 / wrench, int. hex. screw / chiave a brugola . . .	1
6	277 810	Sechskant-Stiftschlüssel 6 / wrench, int. hex. screw / chiave a brugola . . .	1
7	277 830	Schraubenziehereinsatz / insert for screw driver / inserto cacciavite	1
8	277 835	Kreuzschlitzklinge / screw driver blade-Philips / inserto cacciavite . . .	1
9	277 840	Schraubenziehergriff / grip for screw driver / manico cacciavite	1
10	277 825	Ringschlüssel 22x24 mm / ring wrench / chiave a stella	1
11	276 040	Konterschlüssel / wrench, clutch adjustment / chiave frizione	1
12	876 195	Werkzeugtasche / tool bag / busta per attrezzi	1
13	277 850	Montagestempel für WD-Ring 230 355 / oil seal insert jig / puntello corteco . . .	1
14	277 870	Montagestempel für WD-Ring 230 421 / oil seal insert jig / puntello corteco . . .	1
15	277 875	Montagestempel für WD-Ring 230 425 / oil seal insert jig / puntello corteco . . .	1

Bild-Nr. Ill. No. Fig.	Teile-Nr. Part No. Codice	B e z e i c h n u n g D e s c r i p t i o n D e s c r i z i o n e	Stück Qty Qtà
16	277 887	Mitnehmerfixierung / clutch hub locking tool / attrezzo bloccaggio frizione	1
17	876 296	Abzieher kpl. für Kurbelwellenlager / puller assy. for bearing on crankshaft / estrattore cuscinetti	1
18	277 890	Ringhälfte für Abzieher / ring half for puller / meta anello per estrattore	2
	276 020	Ringhälfte für Abzieher / ring half for puller / meta anello per estrattore	2
19	977 480	Ring für Abzieher / ring for puller / anello per estrattore	1
20	840 680	Zylinderschraube M8 x 40 / cyl. screw / vite	2
21	277 807	Abzieher für Magnetrad / puller assy. for flywheel / estrattore volano	1
22	277 915	Montagebock / assembly trestle / supporto motore	1
23	241 965	Fixierschraube M8 x 30 / locating bolt for crankshaft / fermo bloccaggio albero motore	1
24	276 190	Montagestempel kpl. für Gehäusering KS / plastic ring insert jig, clutch side / puntello per inserire anelli teflon per cuscinetto	1
25	276 930	Montagestempel kpl. für Gehäusering MS / plastic ring insert jig, magneto side / puntello per inserire anelli teflon per cuscinetto	1
26	276 910	Abziehplatte für Gehäusehälfte / plate for puller, crankcase half / lamina estrattore carter	1
27	840 351	Zylinderschraube M5 x 20 / cyl. screw / vite	4
28	276 920	Schutzkappe / protection cap / cappello protettivo	1
29	276 770	Montagestempel für WD-Ring 230 190 / oil seal insert jig / puntello corteco	1
30	292 124	Dichtungssatz kpl. / gasket set assy. / serie guarnizioni completa	1

Bild-Nr. Ill. No. Fig.	Teile-Nr. Part No. Codice	B e z e i c h n u n g D e s c r i p t i o n D e s c r i z i o n e	Stück Qty Qtà
31	899 786	Schraubensicherungsmittel LOCTITE 242, blau / LOCTITE blue / LOCTITE blu	nach Bedarf as required a richiesta
32	899 683	Flächendichtmittel LOCTITE 515, weinrot / LOCTITE ruby / LOCTITE rosso	- " -